

3-finger self centering gripper pneumatic-series MAC3 *3-Finger Zentrischgreifer pneumatisch-Typ MAC3*

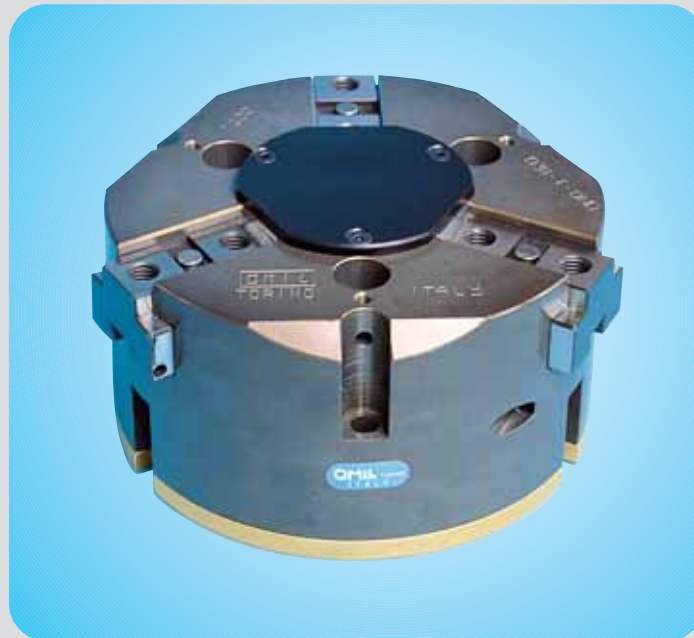

Technische Eigenschaften:

- Betriebsdruck: 2 bis 8 bar
- Wiederholgenauigkeit: MAC3-50...125 0.02mm; MAC3-160...250 0.05mm über 100 Schaltspiele
- Betriebstemperaturbereich von -10°C bis 90°C; bis 130°C und höher auf Anfrage
- Kinematik: Keilhakenprinzip zwangsgeführt über schräge Ebene
- Material : Gehäuse aus hochfester Aluminiumlegierung hartbeschichtet, Funktionsteile aus gehärtetem Stahl
- Betätigung : pneumatisch über gefilterte Druckluft 10µm, trocken oder geölt
- Wartungsfrei: bis 1.5 Mio. Schaltspiele
- Für Innen-und Außengreifen geeignet
- Anschlussmaße der Grundbacken Seite 18
- Schutzart IP40
- Druckluftanschlüsse: über die Seitenflächen-Grundflächen
- M5 Sperrluftanschluss möglich
- 24 Monate Garantie

Technical data:

- Range of operating pressure : 2 - 8 bar
- Repeatability accuracy: MAC3 -50...125 0.02 mm; MAC3 - 160...250 0.05 mm over 100 cycles
- Operating temperature: from -10°C to 90°C; version up to 130°C upon request
- operating principle: wedge-hook kinematics
- Housing material: high tensile hard-coated aluminium alloy, hard-anodized
- Material of functional parts: treated ground steel
- Actuation : compressed air filtered (10 µm), dry or lubricated
- Maintenance: no maintenance required for the first 1.5 million cycles
- Suitable for internal/external gripping
- Layout finger connection page 18
- M5 pressurization
- Air connections: sides and base
- Rating IP 40
- Warranty 24 months

3-finger self centering gripper pneumatic-series MAC3

3-Finger Zentrischgreifer pneumatisch-Typ MAC3

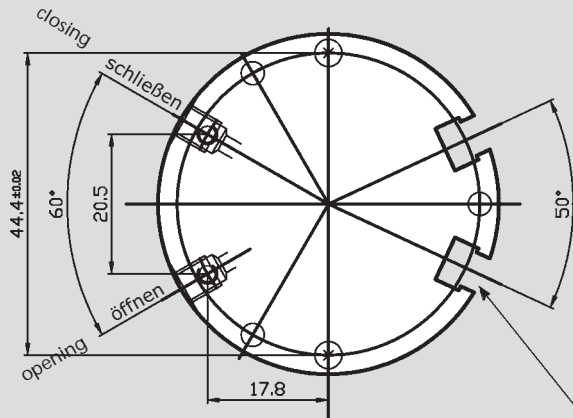

Magnetic limit switch seat
SME8-PS (Festo) or R599 (OMIL)

Hubabfrage über Magnetschalter Typ
SME 8-PS (Festo) oder R599 (OMIL)

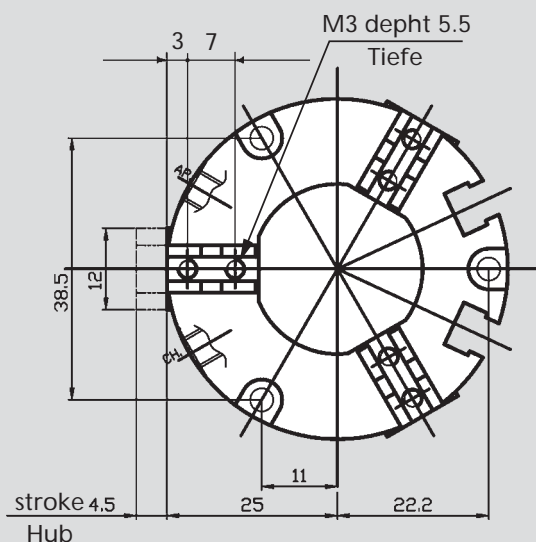
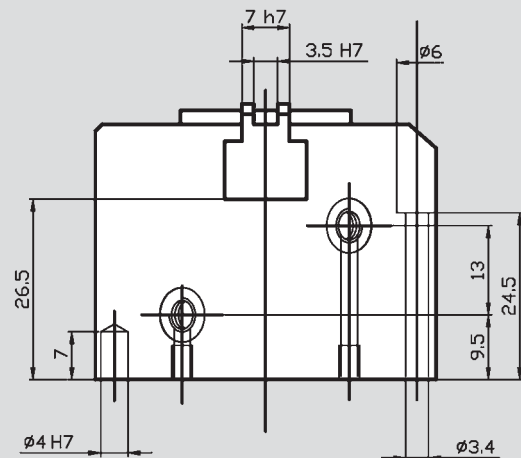
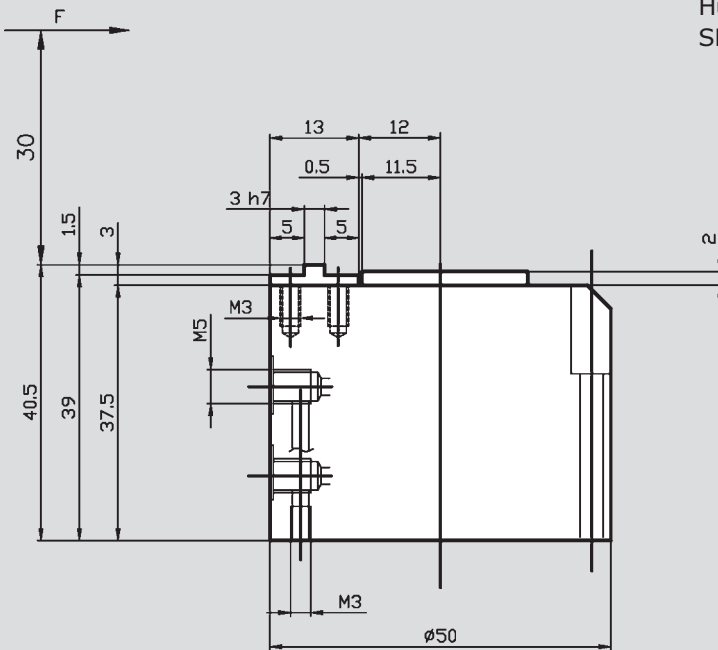

Hose free direct
connection
page 23

Maße für schlauchlosen
Direktanschluss Seite 23

3-finger self centering gripper pneumatic-series MAC3 3-Finger Zentrischgreifer pneumatisch-Typ MAC3

Type	Gripping force at 6 bar (N)	Moment of inertia (Kgcm ²)	Recommended weight of part for transport (kg)	Total air for double stroke consumed (cm ³)	Strike for finger (mm)	Mass (Kg)	Approx. time (s)		Max finger length / weight
Typ	Greifkraft bei 6 bar (N)	Massenträgheitsmoment (Kgcm ²)	Max. empfohlenes Werkstückgewicht (kg)	Luftverbrauch pro Doppelhub (cm ³)	Hub pro Finger (mm)	Mass (Kg)	Schließzeit (s)		Max. Fingerlänge/Eigenmasse
							öffnen	schließen	
MAC3-50	270	0.7	1.35	12	4.5	0.22	0.03	0.03	50/0.15

Transportable weight calculated with $\mu = 0.1$ and $f_s = 2$. With form-fit gripping the mass may be greater. The gripping force is the arithmetic sum of the individual forces created at the fingers at "1" mm at 6 bar. Finger weight in Kg.

Empfehlung für max. Werkstückgewicht gerechnet mit $\mu = 0.1$ $f_s = 2$. Bei Formschluss sind größere Massen möglich. Die Greifkraft ist die arithmetische Summe der an den Greifbacken auftretenden Einzelkräfte im Abstand "1" in mm bei 6 bar. Eigenmasse in Kg.

Gripping force safety device Code MC (closing) MA (opening)

Maßangaben für Greifer mit Greifkraftsicherung Version MC (schließen) MA (öffnen)

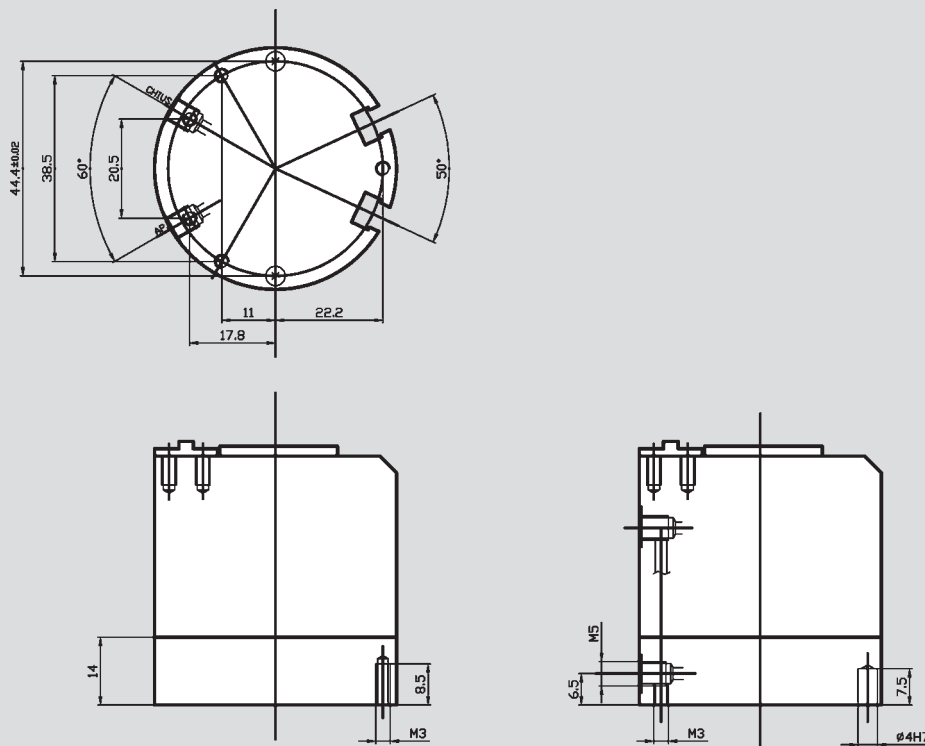

Type	Gripping force of spring only (N) with fixed elasticity		Gripping time (s) with spring only (pneumatic)
Typ	min	max	
	Schließkraft über Feder in (N) beim Außenspannen		Schließzeit nur über Feder (s)
	min	max	
MAC3-50	110	160	0.05

NOTE: Minimum operating pressure 4.5 bar. Upon request versions with less pressure; in this case the spring force will be lower. Gripping force = pneumatic gripping force + spring force. The gripping force is the arithmetic sum of the individual forces of the fingers.

Bemerkung: Betriebsdruck mindestens 4.5 bar. Die Greifkraft ergibt sich aus der pneumatischen Greifkraft + Federkraft. Die Greifkraft ist die arithmetische Summe der an den Greifbacken auftretenden Einzelkräfte im Abstand "1" bei 6 bar

3-finger self centering gripper pneumatic-series MAC3 3-Finger Zentrischgreifer pneumatisch-Typ MAC3

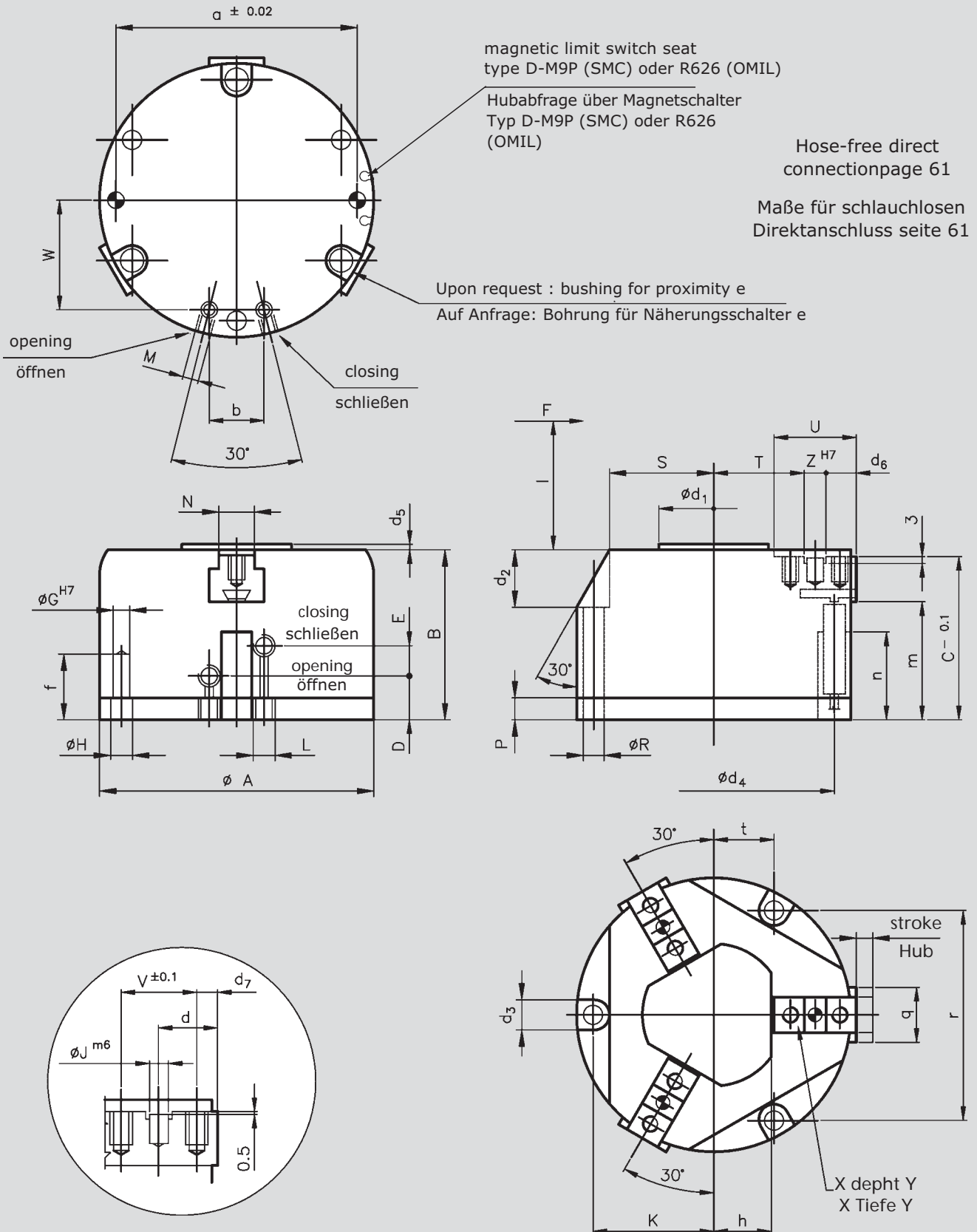

3-finger self centering gripper pneumatic-series MAC3 3-Finger Zentrischgreifer pneumatisch-Typ MAC3

Type Typ	A	B	C	D	E	G	H	L	M	N	P	R	S	T	U	V	Z	Y	X	W	J	K
MAC3 64	64	43	41	11	11	4	4.5	M4	M5	11	5	5.5	24	19.5	21	13	5	6.5	M4	24.5	4	27.5
MAC3 80	80	49	46	11.5	13.5	5	5.5	M5	M5	13	5	6.5	30	26.5	25.5	16	6	8	M5	33	5	34.5
MAC3 100	100	59	56	15	13.5	5	5.5	M5	1/8	15	6	6.5	40	32	32	20	8	10	M6	41	6	44
MAC3 125	125	71	67	16	20	6	6.5	M5	1/8	18	9	9	50	41.5	40.5	24	8	12	M8	52	6	55
MAC3 160	160	85	81	18	25	6	6.5	M5	1/8	22	8	9	65	55	50	32	10	15	M10	66	8	72
MAC3 200	200	125	121	23	46	10	10.5	1/8	1/4	30	12	13	85	67	62	40	14	20	M12	80	12	90
MAC3 250	249	150	142	22.5	56.5	12	13	1/8	1/4	36	12	17	95	84	80	48	16	22	M12	100	12	112

Type Typ	a	b	d	d ₁	d ₂	d ₃	d ₄	d ₅	d ₆	d ₇	e	f	h	l	m	n	q	r	t	
MAC3 64	55	17	10.5	26	18	10	54	2	8	4	∅4	M5	15	11	23	27.5	19	18	47.5	14
MAC3 80	69	18	13	40	19	11	69	3	10	5	∅4	M8	18	17	28	31.5	22	21	60	17
MAC3 100	88	25	16	50	24	11	88	3	12	6	∅6.5	M8	19	19	34	38	28	25	76	22
MAC3 125	110	30	20.5	55	25	14	112	3	16.5	8.5	∅6.5	M8	23	25	38	45	33	32	95	27.5
MAC3 160	144	38	25	80	37	14	144	3	20	9	∅6.5	M8	23	34	45	55	36	40	125	36
MAC3 200	180	42	31	90	38	19	180	4	24	11	M8	M12	27	42.5	55	80.5	56	48	156	45
MAC3 250	224	56	41	115	46	25	230	5	33	17	M8	M12	30	52	60	94	72	56	194	56

Type	Stroke for finger (mm)		Gripping force at 6 bar (N)		Air consum for double stroke (cm ³)	Gripper weight (Kg)	Recommended weight of part for transport (kg)		Approx. time (s)		Moment of inertia (Kgcm ²)	Max finger length / weight
Typ	Hub pro Finger (mm)		Greifkraft bei 6 bar (N)		Luftverbrauch pro Doppelhub (cm ³)	Mass (Kg)	Max. empfohlenes Werkstückgewicht		Schließzeit (s)		Massenträgheitsmoment (Kgcm ²)	Max. Fingerlänge Eigenmasse
	Vers1	Vers 2	Vers 1	Vers 2			Vers 1	Vers 2	öffnen	schließen		
MAC3 64	6	3	580	970	20	0.4	3	5	0.02	0.02	2	64/0.32
MAC3 80	8	4	1000	2300	39	0.75	5	11.5	0.05	0.05	6	80/0.55
MAC3 100	10	5	1800	4050	90	1.4	9	20	0.08	0.08	18	100/1.05
MAC3 125	13	6.5	3000	5800	175	2.4	15.5	29	0.16	0.16	47	125/2
MAC3 160	16	8	6000	11000	423	4.9	25	50	0.4	0.4	157	160/3.3
MAC3 200	25	12.5	7100	16000	910	11.5	35	80	1	1	575	200/6.4
MAC3 250	30	15	10300	18600	1810	21.5	51	93	1.4	1.4	1680	250/8.7

Transportable weight calculated with $\mu = 0.1$ and $f_s = 2$. With form-fit gripping the mass may be greater.
The gripping force is the arithmetic sum of the individual forces created at the fingers at "l" mm at 6 bar. Finger weight in Kg.
Empfehlung für max. Werkstückgewicht gerechnet mit $\mu = 0.1$ $f_s = 2$. Bei Formschluss sind größere Massen möglich. Die Greifkraft ist die arithmetische Summe der an den Greifbacken auftretenden Einzelkräfte im Abstand "l" in mm bei 6 bar. Eigenmasse in Kg

Hose-free direct connection

Maße für schlauchlosen Direktanschluss

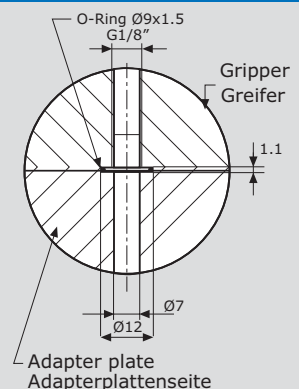
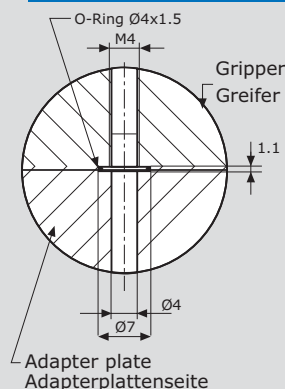
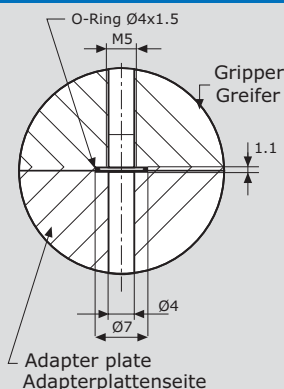

3-finger self centering gripper pneumatic-series MAC3 3-Finger Zentrischgreifer pneumatisch-Typ MAC3

Allowed load data

Maximal zul. Kräfte und Momente am Finger

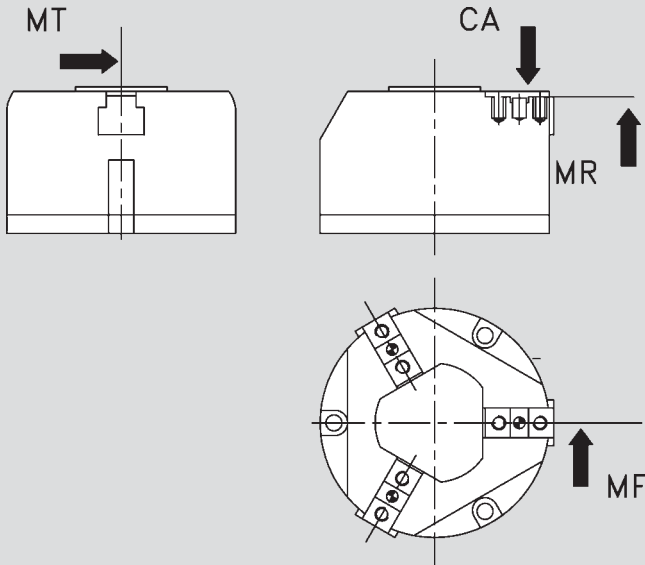

Type Typ	CA (N)	MR (Nm)	MF (Nm)	MT (Nm)
MAC3 50	480	15	12	12
MAC3 64	1350	35	30	15
MAC3 80	1820	85	35	35
MAC3 100	2250	95	50	45
MAC3 125	2500	100	70	65
MAC3 160	2800	110	85	85
MAC3 200	3500	135	100	120
MAC3 250	4450	205	155	170

Spring packaged pressure plate - code P

Federnder Andrückstern P

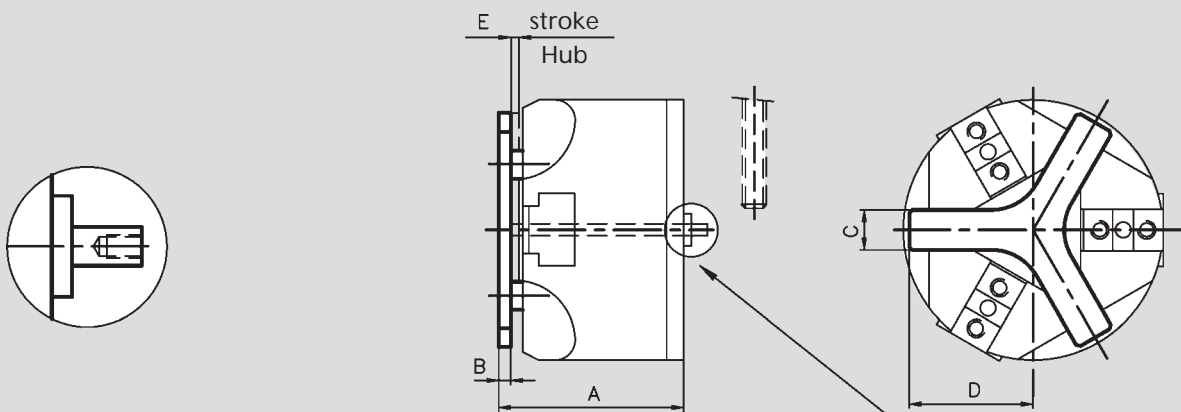

Type Typ	A	B	C	D	E	Thrust Kraft
MAC3 50	45.5	3	10	23	3	8-20N
MAC3 64	54	7	11	30	4	13-55N
MAC3 80	60	7	12	37	4	15-72N
MAC3 100	72	8	16	48	5	15-100N
MAC3 125	85	8	20	60	6	125-250N
MAC3 160	100	9	24	75	6	170-280N
MAC3 200	143	11	32	95	7	310-480N
MAC3 250	171	14	40	115	7	390-710N

upon request : passing rod (except MAC3-64)

Auf Anfrage: Hubabfrage des Andrücksterns (außer MAC3-64)

3-finger self centering gripper pneumatic-series MAC3

3-Finger Zentrischgreifer pneumatisch-Typ MAC3

Force at 6 bar in N at l mm

Greifkraft (N) in Abhängigkeit der Fingerlänge "l" (mm) bei 6 bar

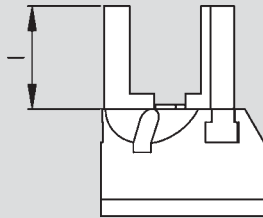

- code 1 closing (dotted line)
- code 2 closing _____ (solid line)
- Vers 1 Außenspannen
- Vers 2 Außenspannen

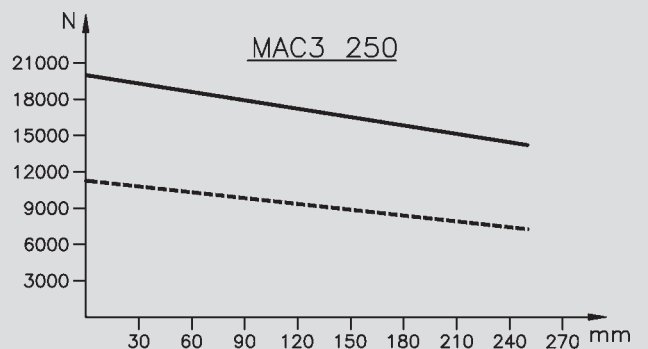
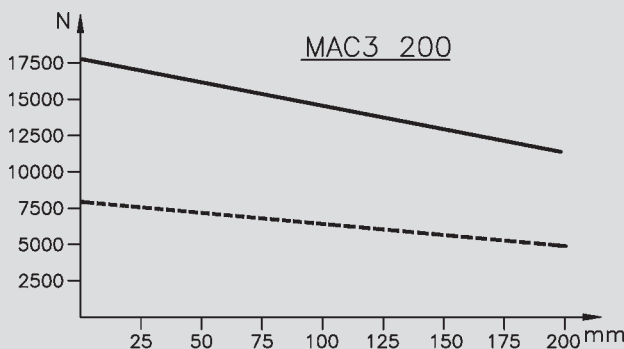
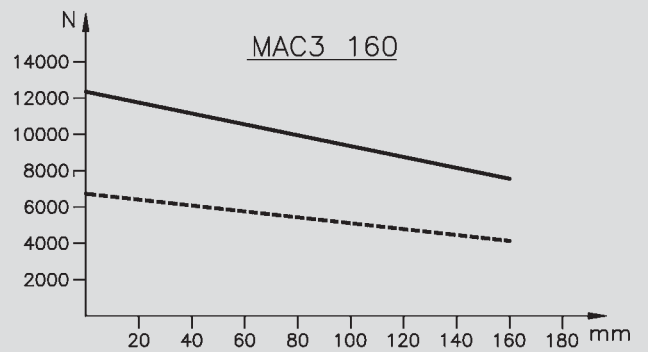
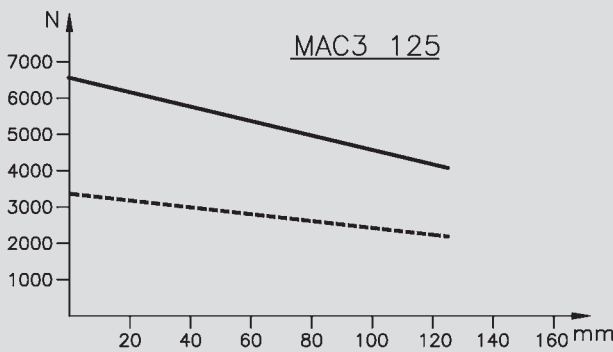
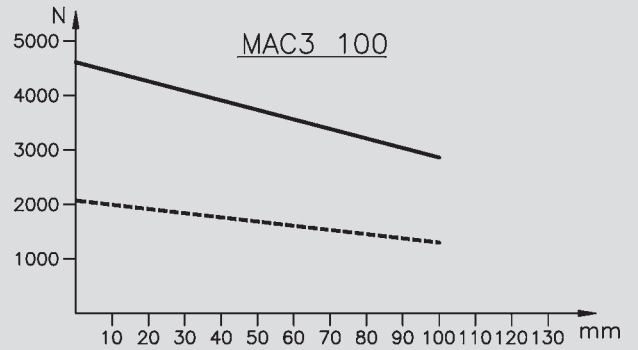
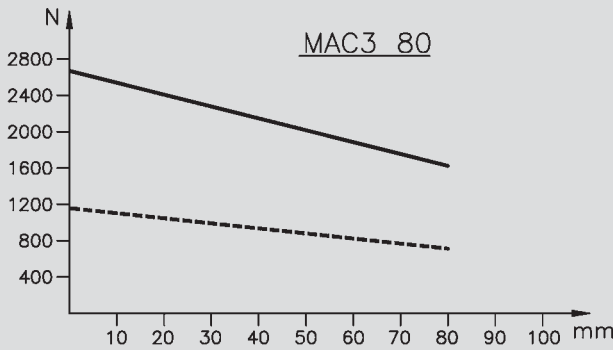
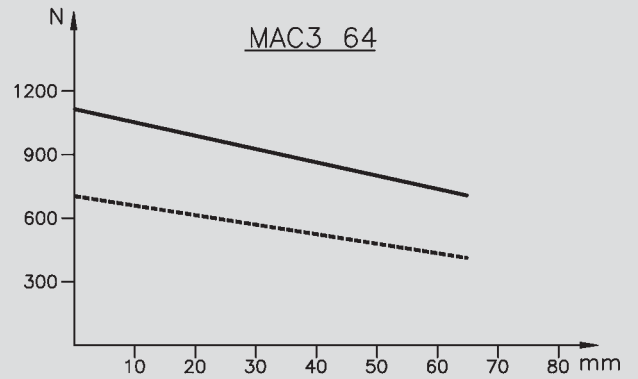

3-finger self centering gripper pneumatic-series MAC3 3-Finger Zentrischgreifer pneumatisch-Typ MAC3

Gripping force safety device
code MC (closing) MA (opening)

Maßangaben für Greifer mit
Greifkraftsicherung Version MC
(schließen) MA (öffnen)

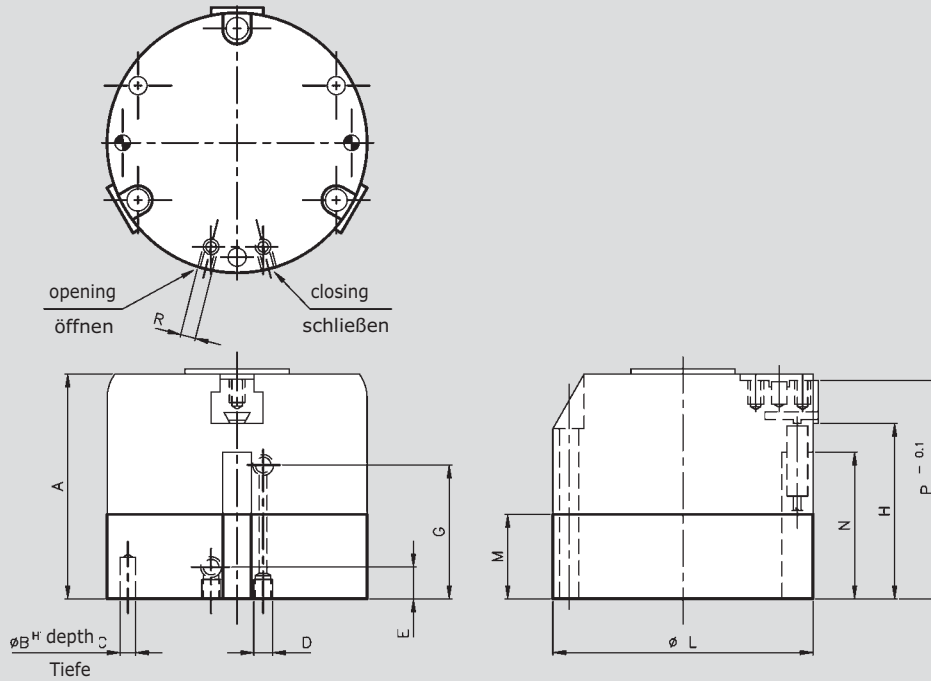

Type	A	B	C	D	E	G	H	L	M	N	P	R	Gripping force with only spring (N) with fixed elasticity				Gripping time (s) with spring	Mass (Kg)
													code 1		code 2			
Type	A	B	C	D	E	G	H	L	M	N	P	R	Schließkraft über Feder in (N) beim Außenspanne				Schließzeit nur über Feder (s)	Masse (Kg)
													Vers 1		Vers 2			
													min	max	min	max		
MAC3 64	57	4	10	M4	7	36	41.5	64	19	33	55	M5	160	230	380	610	0.06	0.5
MAC3 80	68	5	13	M5	8	44	50.5	80	24	41	65	M5	290	660	780	1350	0.09	0.9
MAC3 100	82	5	13	M5	11	51.5	61	100	29	51	79	1/8	700	1300	1400	2800	0.16	1.65
MAC3 125	94	6	15	M5	13	59	68	125	32	56	90	1/8	950	1830	2000	3600	0.25	2.85
MAC3 160	115	6	18	M5	14	73	85	160	38	66	111	1/8	1480	2900	2970	5750	0.7	5.6
MAC3 200	170	10	16	1/8	14	114	125.5	200	57	101	166	1/4	1850	3870	3500	7100	1.4	13.5
MAC3 250	205	12	20	1/8	14	134	149	249	67	127	197	1/4	3000	6800	5400	12200	2	24.5

NOTE: Minimum operating pressure 0.45 MPa. Upon request versions with less pressure; in this case the spring force will be lower. Gripping force = pneumatic gripping force + spring force. The gripping force is the arithmetic sum of the individual forces of the fingers.

Bemerkung: Betriebsdruck mindestens 4.5 bar. Die Greifkraft ergibt sich aus der pneumatischen Greifkraft + Federkraft. Die Greifkraft ist die arithmetische Summe der an den Greifbacken auftretenden Einzelkräfte im Abstand "I" bei 6 bar

Ordering example

Bestellbeispiel

Type	Code 1 or 2	For internal bushes indicate B + level	For spring packaged pressure plate	For safety device indicate MC or MA	For passing rod indicate C
Typ	Vers 1 od. 2	Für Ausführung mit Nahrungsschalter B+Durchmesser	Für federnden Andrückstern P	Für federgestützte Greifkraftsicherung MC oder MA	Für Hubabfrage des Andrückstern C
MAC3 100	C1	B8	P	MC	/