

4-finger self centering gripper pneumatic - series MA4 4-Finger-Zentrischgreifer pneumatisch - Typ MA 4



Technische Eigenschaften:

- Betriebsdruck: 2 bis 8 bar
- Wiederholgenauigkeit: MA4-75...110 0.02mm; MA4-175...230 0.05mm über 100 Schaltspiele
- Betriebstemperaturbereich von -10°C bis 90°C; bis 130°C und höher auf Anfrage
- Wirkprinzip: Keilhakenprinzip zwangsgeführt über schräge Ebene
- Material : Gehäuse aus hochfester Aluminiumlegierung hartbeschichtet, Funktionsteile aus gehärtetem Stahl
- Betätigung : pneumatisch über gefilterte Druckluft 10µm, trocken oder geölt
- Wartungsfrei: bis 1.5 Mio. Schaltspiele
- Für Innen-und Außengreifen geeignet
- Anschlussmaße der Grundbacken Seite 18
- Schutzart IP40
- Druckluftanschlüsse: über die Seitenflächen-Grundflächen
- 24 Monate Garantie

Technical data:

- Range of operating pressure : 2 - 8 bar
- Repeatability accuracy: MA4-75..110 0.02 mm; MA4-145..230 0.05 mm over 100 cycles;
- Operating temperature: from -10°C to 90°C; version up to 130°C upon request
- Operating principle: wedge-hook kinematics
- Housing material: high tensile hard-coated aluminium alloy, hard-anodized
- Material of functional parts: treated ground steel
- Actuation : compressed air filtered (10 µm), dry or lubricated
- Maintenance: no maintenance required for the first 1.5 million cycles
- Suitable for internal/external gripping
- Layout finger connection page 18
- Air connections: sides and base
- Rating IP 40
- Warranty 24 months

4-finger self centering gripper pneumatic - series MA4

4-Finger-Zentrischgreifer pneumatisch - Typ MA 4

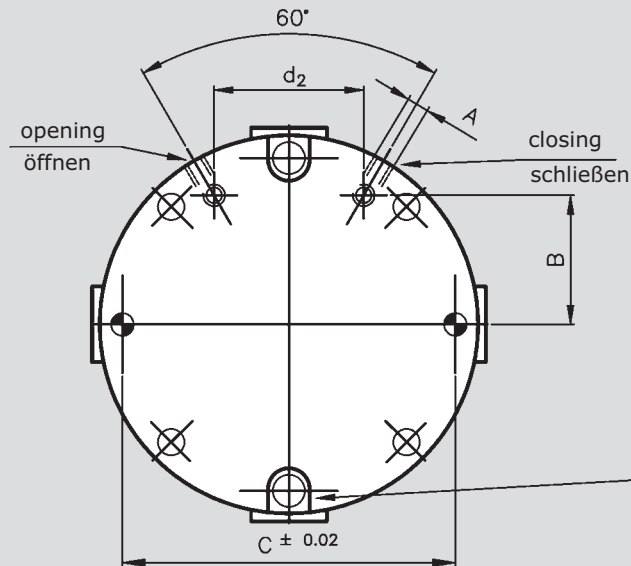

Upon request: bush for proximity e
Auf Anfrage: Bohrung für Näherungsschalter e

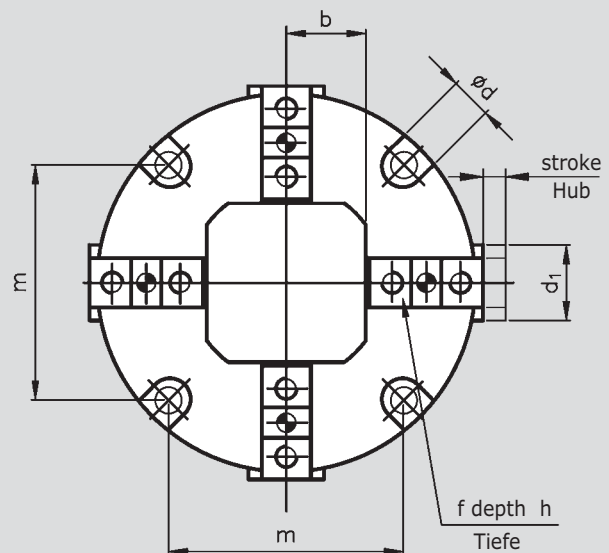
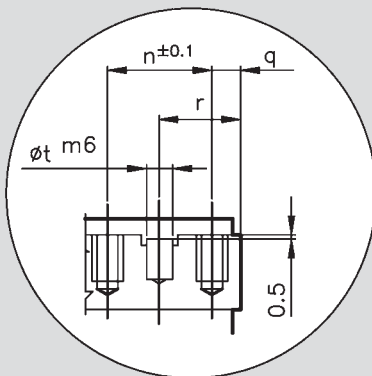
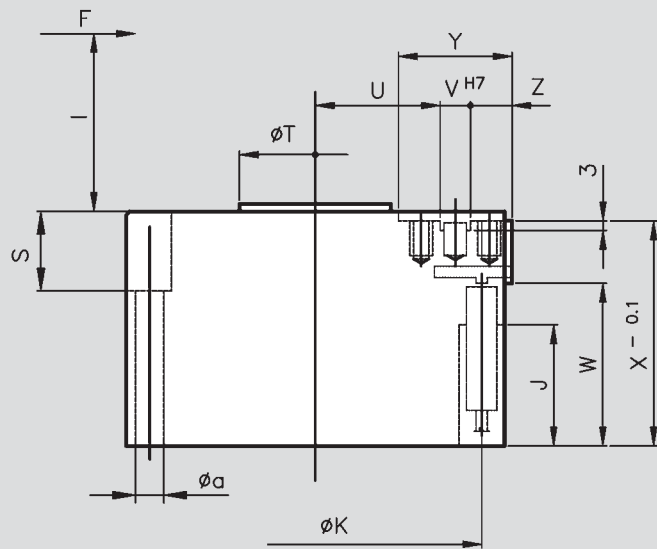
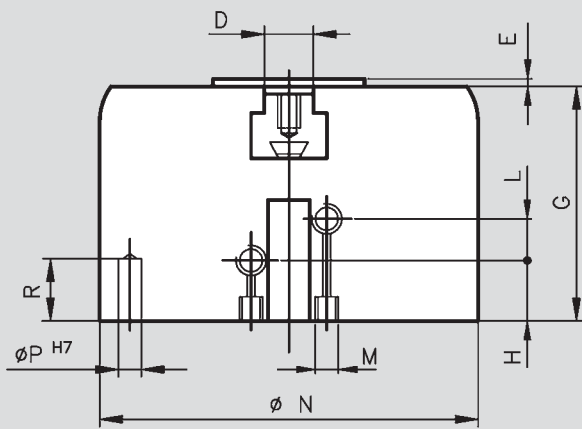

4-finger self centering gripper pneumatic - series MA4 4-Finger-Zentrischgreifer pneumatisch - Typ MA 4

Type	A	B	C	D	E	G	H	L	M	N	P	R	S	T	U	V	Z	Y	X	W	J	K	
Typ																							
MA4 75	M5	28	64	11	3	50	11	18	M4	74	5	9	16	44	25	5	8	21	48	35.5	24	63	
MA4 95	1/8	35	84	13	3	59	12	22	M5	94	6	10	25	54	32	6	10	25.5	56	42	31	82	
MA4 110	1/8	40	100	15	3	71	17	24	M5	110	6	10	30	58	38	8	12	32	68	50	38	98	
MA4 145	1/8	54	130	18	3	90	17	34	M5	144	8	12	38	72	48.5	8	16.5	40.5	86	66	50	130	
MA4 185	1/8	72	166	22	3	106	20	38	M5	186	10	16	40	90	64	10	20	50	102	76	54	166	
MA4 230	1/4	90	208	30	4	136	21	51	1/8	228	12	20	58	110	77	14	24	62	132	92	68	210	

Type	a	b	d	d ₁	d ₂	e	f	h	l	m	n	q	r	t	Max finger length/weight (kg)	
Typ															Max.Fingerlänge Eigenmasse(kg)	
MA4 75	5.5	16.5	10	18	27	∅4	M5	M4	6.5	23	46	13	4	10.5	4	64 / 0.3
MA4 95	6.5	22	11	21	34	∅4	M8	M5	8	28	59	16	5	13	5	80 / 0.5
MA4 110	6.5	25.5	11	25	46	∅6.5	M8	M6	10	34	71	20	6	16	6	100 / 0.95
MA4 145	9	32	14	32	64	∅6.5	M8	M8	12	38	92	24	8.5	20.5	6	125 / 1.75
MA4 185	11	43.5	17	40	82	∅6.5	M8	M10	15	45	117.5	32	9	25	8	160 / 3
MA4 230	13	52.5	20	48	104	∅6.5	M8	M12	20	55	147	40	11	31	12	200 / 5.5

Type	Gripper stroke		Gripping force at 6 bar (N)		Air consum for double stroke (cm ³)	Gripper weight (kg)	Recommended weight of part for transport (kg)		Approx. time (s)		Moment of inertia (Kgcm ²)
	code 1	code 2	code 1	code 2			code 1	code 2	opening	closing	
Typ	Hub pro Finger(mm)		Greifkraft bei 6 bar (N)		Luftverbrauch pro Doppelhub (cm ³)	Masse (Kg)	Max. empfohlenes Werkstückgewicht (kg)		Schließzeit (s)		Massen trägheits moment (Kgcm ²)
	Vers 1	Vers 2	Vers 1	Vers 2			Vers 1	Vers 2	öffnen	schließen	
MA4 75	6	3	770	1290	21	0.8	3	5	0.03	0.03	5.5
MA4 95	8	4	1330	3060	50	1.5	5.5	12	0.07	0.07	16.6
MA4 110	10	5	2400	5330	111	2	9.5	21	0.1	0.1	30.2
MA4 145	13	6.5	4130	7700	217	4.4	16	30	0.18	0.18	114
MA4 185	16	8	8000	14670	477	8.5	30	56	0.45	0.45	367.6
MA4 230	25	12.5	11200	25380	1246	16.8	42	90	1.2	1.2	1091.7

Transportable weight calculated with $\mu = 0.1$ and $f_s = 2.5$ With form-fit gripping the mass may be greater. The gripping force is the arithmetic sum of the individual forces created at the fingers at "l" mm at 6 bar.

Empfehlung für max. Werkstückgewicht gerechnet mit $\mu = 0.1$ $f_s = 2$. Bei Formschluss sind größere Massen möglich. Die Greifkraft ist die arithmetische Summe der an den Greifbacken auftretenden Einzelkräfte im Abstand "l" in mm bei 6 bar. Eigenmasse in Kg.

Hose free direct connection

Maße für schlauchlosen Direktanschluss

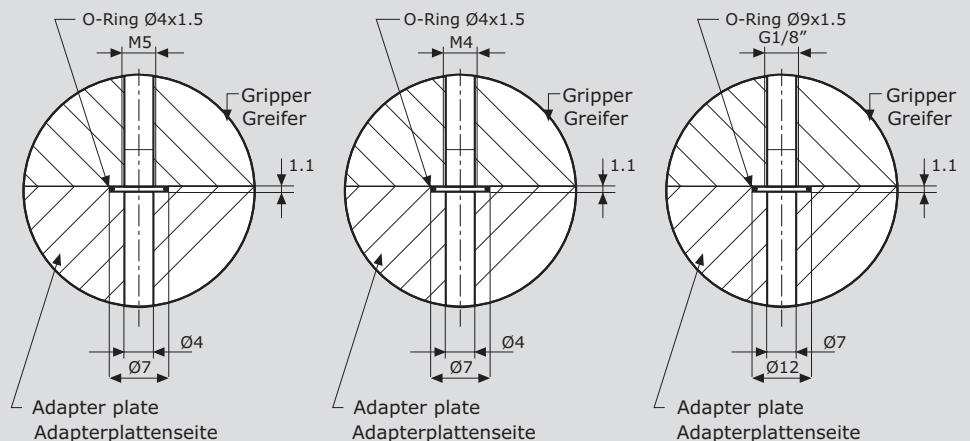

4-finger self centering gripper pneumatic - series MA4 4-Finger-Zentrischgreifer pneumatisch - Typ MA 4

Allowed load data

Maximal zul. Kräfte und Momente am Finger

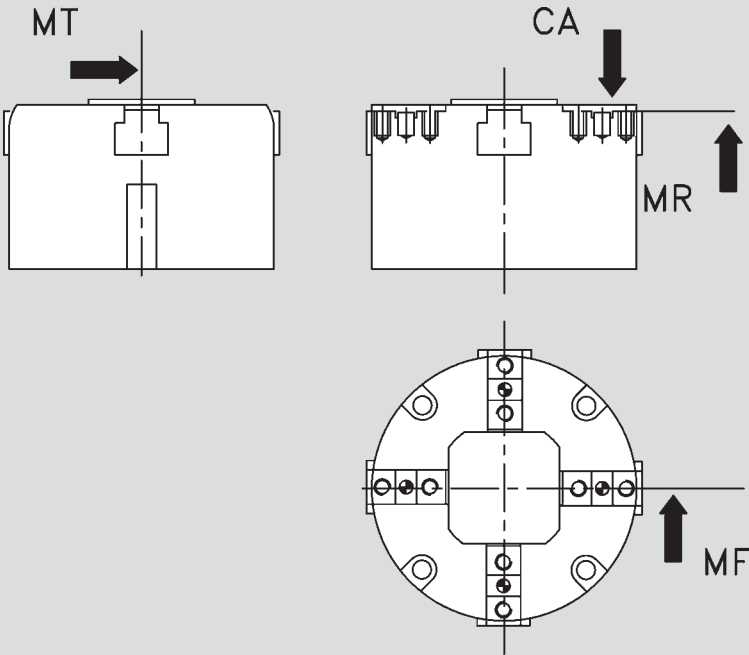

Type Typ	CA (N)	MR (Nm)	MF (Nm)	MT (Nm)
MA4 75	1350	35	30	15
MA4 95	1820	85	35	35
MA4 110	2250	95	50	45
MA4 145	2500	100	70	65
MA4 185	2800	110	85	85
MA4 230	3500	140	100	120

Spring packaged pressure plate - cod. P

Federnder Andrückstern P

Upon request: passing rod (except MA4-75)

Auf Anfrage: Hubabfrage des Andrücksterns (außer MA 4-75)

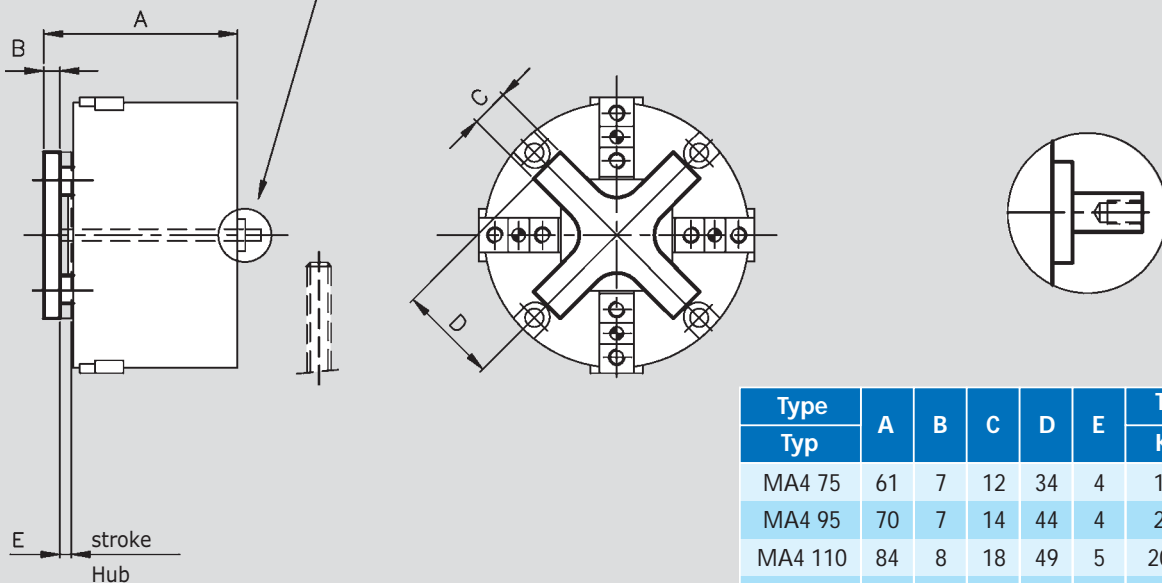

Type Typ	A	B	C	D	E	Thrust Kraft
MA4 75	61	7	12	34	4	17-75N
MA4 95	70	7	14	44	4	20-95N
MA4 110	84	8	18	49	5	20-130N
MA4 145	104	8	22	63	6	160-330N
MA4 185	121	9	28	79	6	220-370N
MA4 230	154	11	36	99	7	410-640N

4-finger self centering gripper pneumatic - series MA4 4-Finger-Zentrischgreifer pneumatisch - Typ MA 4

Force at 6 bar in N at l mm

Greifkraft (N) in Abhängigkeit der Fingerlänge "l" (mm) bei 6 bar

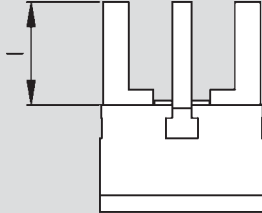

- code 1 closing - Version 1 Außenspannen
- code 2 closing - Versione 2 Außenspannen

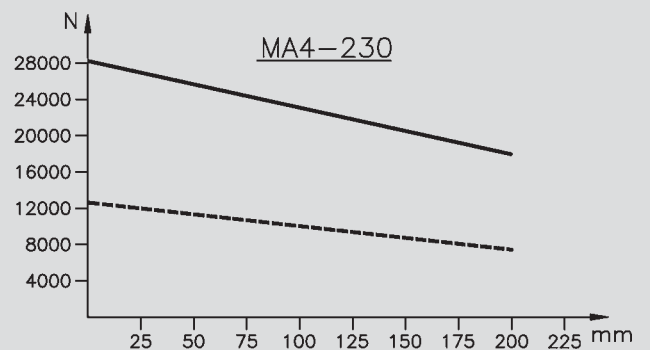
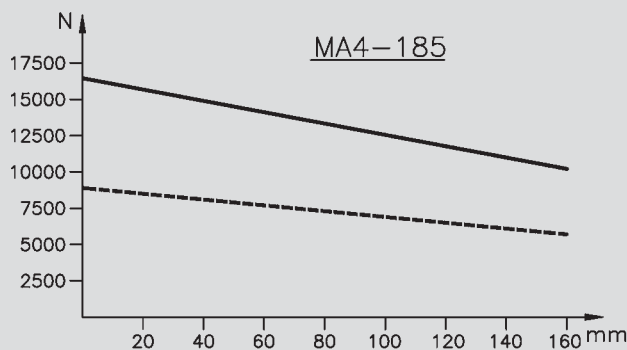
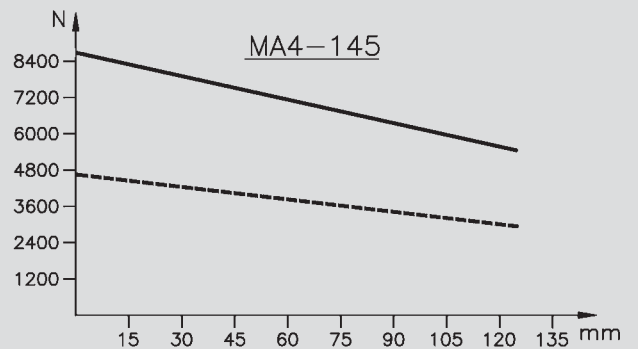
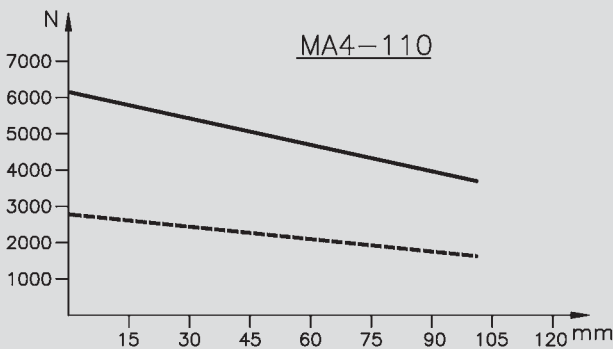
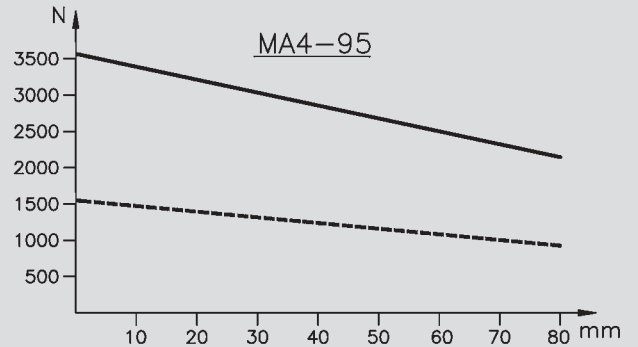
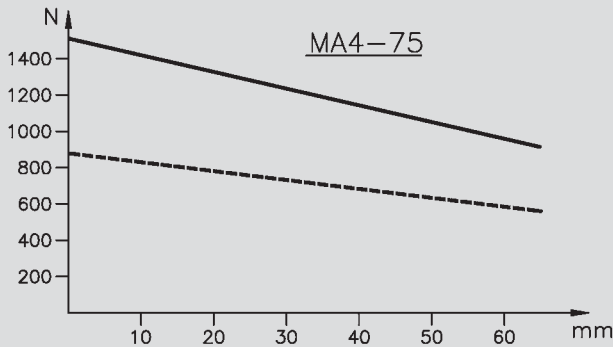

4-finger self centering gripper pneumatic - series MA4 4-Finger-Zentrischgreifer pneumatisch - Typ MA 4

Gripping force safety device code MC (closing) MA (opening)

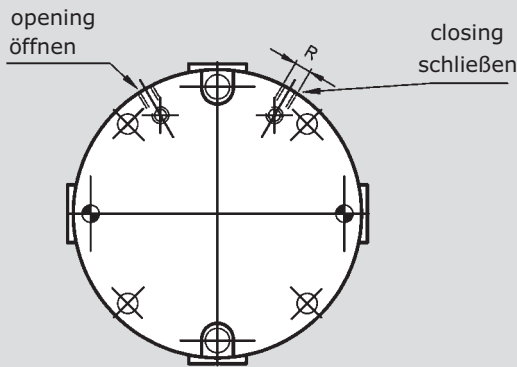

Maßangaben für Greifer mit Greifkraftsicherung Version MC (schließen) MA (öffnen)

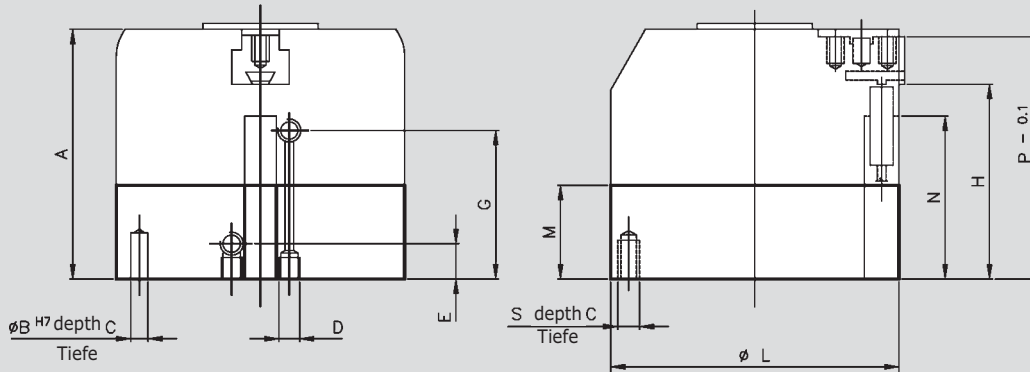

Type	Gripping force with only spring in N with fixed elasticity				Gripping time (s) with spring only	Mass (Kg)	A	B	C	D	E	G	H	L	M	N	P	R	S
	code 1 min	code 1 max	code 2 min	code 2 max															
MA4 75	200	290	530	820	0.06	1	66	5	8	M4	8	46	51.5	74	16	40	64	M5	M5
MA4 95	400	860	1100	1730	0.1	1.7	81	6	10	M5	11	56	64	94	22	53	78	1/8	M6
MA4 110	1000	1800	1900	3700	0.18	2.3	94	6	12	M5	11	64	73	110	23	61	91	1/8	M6
MA4 145	1300	2500	2620	4600	0.29	4.8	120	8	15	M5	13	81	96	144	30	80	116	1/8	M8
MA4 185	1900	3870	3900	7400	0.75	9.1	141	10	20	M5	13	93	111	186	35	89	137	1/8	M10
MA4 230	3100	5800	5900	10000	1.6	17.8	181	12	24	1/8	14	117	137	228	45	113	177	1/4	M12

NOTE: Minimum operating pressure 4.5 bar. Upon request versions with less pressure; in this case the spring force will be lower. Gripping force = pneumatic gripping force + spring force. The gripping force is the arithmetic sum of the individual forces of the fingers.

Bemerkung: Betriebsdruck mindestens 4.5 bar. Die Greifkraft ergibt sich aus der pneumatischen Greifkraft + Federkraft. Die Greifkraft ist die arithmetische Summe der an den Greifbacken auftretenden Einzelkräfte im Abstand "I" bei 6 bar

Ordering example

Bestellbeispiel

Type	Code 1 or 2	For internal bushes indicate B + level	For spring packaged pressure plate	For safety device indicate MC or MA	For passing rod indicate C
Typ	Version 1 od. 2	Für Ausführung mit Nährungs-schalter B+Durchmesser	Für federnden Andrückstern P	Für federgestützte Greifkraftsicherung MC oder M	Für Hubabfrage des Andrückstern C
MA4 110	C1	B8	P	MC	/